

Bourdon tube pressure gauge for diaphragm seals and switch contact Type series BR42..



SIL2

Application area

- Pharmaceutical industry
- Food industry
- Biotechnology

Features

- Bourdon tube pressure gauge for diaphragm seal and switch contact
- Nominal range -1...3 bar to -1...15 bar, 0...4 bar to 0...400 bar
- High quality case with bajonet ring NS 100
- Case, measuring element and pressure connection of stainless steel
- Instrument connection welded with diaphragm seal
- Small temperature error by means of reduced-volume measuring element
- Process connection via diaphragm seal product group D5
- Switch contacts (electrical contact devices) per DIN 16085:
 - slow acting contact
 - magnetic snap contact
 - inductive contact
 - inductive contact with integrated switching amplifier

Options

- Labom REconnect quick coupling device for easy and safe separation and connection of diaphragm seal systems; Type series MK1000, see data sheet D6-022
- Approvals/Certificates
 - Ex-protection (ATEX/UKEX)
 - Classification per SIL2
 - Material certificate per EN 10204-3.1
 - Calibration certificate per EN 10204-3.1
- As per UKCA regulations
- Higher overload protection
- Case with liquid filling
- Damping of movement
- Electronical angle-of-rotation sensor, Type series PL1100, see data sheet D6-020
- Connection to Zone 0 by using the flame arrester MF21xx, see data sheet D6-025
- Extended neck tube

Application

This bourdon tube pressure gauge with switch contact has been especially constructed for the operation with diaphragm seals. A custom bourdon tube that is reduced in volume produces a very slight temperature error. Diaphragm seals with reduced diaphragm surface areas may also be used. A large selection of diaphragm seals – D5 product category – is available for a variety of applications.

Technical data

Constructional design / case

Design:	High quality case with bayonet ring, material: st. steel mat.-no. 1.4301 (304) ventilation valve, material: PUR	
Nominal size:	NS 100	
Degree of protection per EN 60529:	IP 65	
Case filling:	Labofin	
Atmosph. pressure compensation:	Via ventilation valve.	
Case seal:	Material gasket: NBR	
Window:	Non splintering laminated glass	
Contact lock:	Stainless steel with NBR gasket	
Measuring element:	Bourdon tube < 60 bar: c-type ≥ 60 bar: spiral	
Movement:	Stainless steel segment Optional: movement with integrated damping system	
Scale:	Pure aluminium, white with black inscription. Option: with red marking, special scale upon request.	
Pointer:	Pure aluminium, black. With micro adjustment for zero point correction.	
Electronical connection:	Connection plug with cable gland M20 x 1.5 and removable test cover, material: Macrolon	
Weight:	NS 100 without filling:	approx. 1.0 kg
	NS 100 with filling:	approx. 1.5 kg

Process connection

Design:	Via diaphragm seal technology, see order details and product group D5
---------	---

Nominal range

See order details, further ranges upon request

Overload-protection:	standard: 1.3 times higher overload protection see order details
----------------------	---

Accuracy

Accuracy class:	nominal range (bar)	number of contacts	
		1	2
	4	cl. 2.5	-
	6	cl. 1.6	cl. 2.5
	≥ 10	cl. 1	cl. 1
		Plus effect of switch function on indication per DIN 16085.	
Temperature influence:	Max. ± 0.4% / 10K of measuring span per EN 837-1		
Temperature influence media:	Temperature error due to diaphragm seal system.		
	dM 22...24 mm	≤ 30 mbar / 10 K	
	dM 27...30 mm	≤ 20 mbar / 10 K	
	dM 34...36 mm	≤ 8 mbar / 10 K	
	dM 40...46 mm	≤ 5 mbar / 10 K	
	dM 51...58 mm	≤ 2 mbar / 10 K	
	A detailed calculation of accuracy can be submitted upon request.		
	Deviations in case of special materials.		

Temperature ranges

Temperature ranges for the design of the diaphragm seal system (in combination with the pressure transmission fluid FD1):

Ambient:	-10...50 °C
Media:	-10...140 °C

Adjusted design temperature ranges within the following maximum values are possible on request:

	without filling	with filling
Ambient:	-20...60 °C	-20...50 °C
Media:	-40...230 °C (-20...70 °C) ¹	-40...190 °C (-20...70 °C) ¹

¹ For devices with classification per SIL2

Temperature ranges for storage:

	without filling	with filling
Storage:	-40...70 °C	-40...70 °C

Tests and certificates

Ex-protection: Magnetic snap contact:
Simple electrical apparatus per EN 60079-11 suitable for intrinsically safe circuits Ex IIC TX.

Inductive contact:
Contact device suitable for intrinsically safe circuits

⊕ II 2G Ex ia IIC T4/T5/T6 Gb

ATEX ■ PTB 99 ATEX 2219X
■ PTB 00 ATEX 2049X

UKEX: ■ CML 21UKEX2893X
■ CML 21UKEX2977X

Ex-protection (ATEX/UKEX) for mechanical devices:

⊕ II 2G Ex h IIC T1...T6 Gb X

⊕ II 2D Ex h IIC Txx°C Db X

Further details see operation instruction BA_037 and Ex Instructions XA_005, XA_013 and XA_021.

SIL 2: Functional safety:
per EN 61508, classification per SIL 2, TÜV-Reg.-Nr. 44 799 13190203.
For devices with inductive contact only (Typ N1, N2 and N4).

Switch contacts

Slow acting contact: Type L2

- max. 2 touch contacts
- Contact load: 10 W / 18 VA
- Switching up to 230 V DC
- Available with separate circuit (Type M2)

Magnetic snap contact: Type L4

- max. 2 touch contacts
- Contact load: 30 W / 50 VA
- Switching up to 230 V DC
- Available with separate circuit (Type M4)

Inductive contact: Type N4
(standard)

- max. 2 contacts
- Control unit required, see product group M7

Inductive contact: Type N1
(SN)

- Safety initiator
- max. 2 contacts, contactless
- Control unit required, see product group M7

Inductive contact inverse: Type N2
(S1N)

- Safety initiator, inverse switching
- max. 2 contacts, contactless
- Control unit required, see product group M7

Inductive contact with integrated amplifier: Type N6

- max. 2 contacts, contactless
- 100 mA
- 3-wire technology, suitable for direct activation at a PLC

Further information see operating instruction BA_037 and Technical Information TA_039.

Dimensions

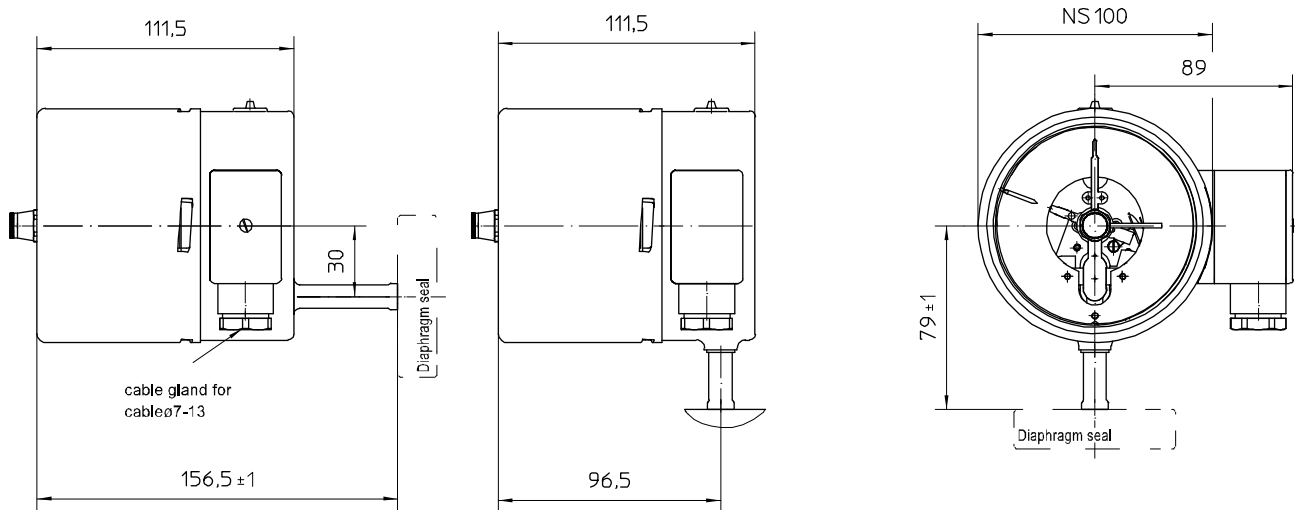

Design with extended neck tube

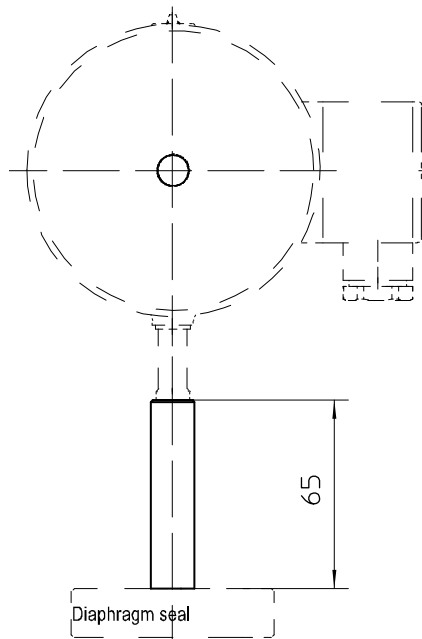

Order details

Bourdon tube pressure gauge with diaphragm seal connection and switch contact Type series BR42..

Order code BR42..			
BR420 .	case design	IP 65 without liquid filling	process connection bottom
BR421 .			process connection at back
BR422 .		IP 65 with liquid filling	process connection bottom
BR423 .			process connection at back
0	design	standard	
1		Ex-protection	

A56	nominal range [bar]	0...4 ¹
A57		0...6 ¹
A58		0...10
A59		0...16
A60		0...25
A61		0...40
A62		0...60
A63		0...100
A64		0...160
A65		0...250
A66		0...400
A89		-1...3 ¹
A90		-1...5 ¹
A91		-1...9
A92		-1...15

	switch contacts	type of contact	number
L4 . 00	touch contact	magnetic snap contact	single contact
L4 . . 0			double contact
L2 . 00		slow acting contact ²	single contact
L2 . . 0			double contact
M4 . . 0		magnetic snap contact, separated circuits	double contact
M2 . . 0		slow acting contact ² , separated circuits	double contact

N4 . 00	Inductive contact	initiator (N)	single contact
N4 . . 0			double contact
N1 . 00		safety initiator (SN)	single contact
N1 . . 0			double contact
N2 . 00		safety initiator invers (S1N)	single contact
N2 . . 0			double contact
N6 . 00		inductiv contact with integrated switching amplifier, 3-wire technology PNP ²	single contact
N6 . . 0			double contact

...	switch function - per contact, replace point with number		
1	switch	rising measured value closes contact	
2		rising measured value opens contact	
4		falling measured value closes contact	
5		falling measured value opens contact	
3	change-over element ³	rising measured value switches	
6		falling measured value switches	

Example of order code switch contacts N4210:

Double inductive contact with initiator → type of contact = N4

1. Inductive contact closes on rising measured value → code number 1
2. Inductive contact opens on rising measured value → code number 2
3. Inductive contact not be used → code number 0

Additional features (to be indicated if required)		
H2	overload protection	2 times, measuring ranges > 25 bar
H3		2.5 times, measuring ranges < 16 bar
K2	neck tube	with extended neck tube (65 mm)
PL1100-...	output signal	4...20mA (20...4 mA) with electr. angle-of-rotation sensor (see M2-030) ⁴
W1020	material certificate	per EN 10204-3.1, wetted parts
W1204	calibration certificate	per EN 10204-3.1, 3 measuring points
W1201		per EN 10204-3.1, 5 measuring points
W2603	functional safety per EN 61508, classification per SIL2 ⁵	
W2660	as per UKCA regulations ⁶	
W4102	damping of movement	with integrated damping system
Process connection		
D...	diaphragm seals see product group D5, welded with instrument connection	

Order code (example): BR4200 – A56 – N4210 - ...

¹ not possible for magnetic snap contact and accuracy class 1 (only for pressure above 10 bar)

² not for devices with Ex-protection

³ possible with touch contacts only (slow acting contact or magnetic snap contact)

⁴ not possible with damping of movement

⁵ for devices with inductive contact only

⁶ not possible with inline diaphragm seals or connection to Inline unit ASEPconnect with pipe diameter > 25 mm