

Pressure Gauge with diaphragm seal series MDI

Pressure gauges with diaphragm flanges
assembled with MAX & MBX
Glycerine / Silicon liquid filled
St. steel case & Diaphragm

General features

- All st. steel pressure gauges
- German movement and sensing element
- Pressure ranges from -1...0 bar to 0...40 bar
- Accuracy class 1.0
- Degree of Protection

Application area

- Diaphragm seals protects the gauges from aggressive, highly viscous or solidifying measurement media as well as from high media temperatures, vapours, measurement pressure fluctuations and pressure spikes as well as increasing the overload capacity.
- Food industry, Pharmaceutical industry, Biotechnology.

General specification

Assembled with pressure gauges with MAX & MBX. All stainless steel pressure gauges, MAX

MAX.51x, 100mm
MAX.41x, 80mm
MAX.31x, 63mm

Wetted parts of Brass, MBX

MBX.51x, 100mm
MBX.31x, 63mm

Accuracy class

MAXK.51x / Class 1.0 per EN 837-1
MAXK.41x / Class 1.6 per EN 837-1
MAXK.31x / Class 1.6 per EN 837-1
MBXK.51x / Class 1.6 per EN 837-1
MBXK.31x / Class 1.6 per EN 837-1

Pressure ranges

-1...0 to 40 bar

Temperature

operating temperature ranges
(ambient and measured medium)
-20...+60°C
storage temperature
-20...+60°C

Case and bezel ring

Material: St. steel
bayonet ring
with blow-out disc at the top of the case



Pressure gauge with chemical seals, series MDI

Type of mounting	Bottom connection
Process Connection	Material St. steel refer to the flange size, See page 2
Bourdon Tube	St. steel for MAX Brass for MBX
Movement	St. steel for MAX Brass for MBX
Diaphragm	St. steel, 316L
Diaphragm housing	St. steel, 316L
Dial	Aluminium, white
Pointer	Aluminium, black
Window	Instrument safety glass
Degree of protection (DIN EN 60 529/IEC 529)	IP 65
Option	case filling 85% - glycerine or silicone
Liquid filling	- Standard : Silicon Oil - Option : Vegetable Oil, High temp. Oil
	Teflon Coating or Lining



DAHO Tronic Limited

Tel: 02-865-7001 Fax: 02-865-7109

mail: info@daho.co.kr

STX W-Tower 209

Gyeongin-ro 53 Gil 90 Guro-gu

Seoul 08215 Korea

Ordering information

Model code

MDI

Selection of pressure gauge

all st. steel

MAXK.51x [100mm]

MAXK.41x [80mm]

MAXK.31x [63mm]

wetted parts, brass

MBXK.51x [100mm]

MBXK.41x [80mm]

MBXK.31x [63mm]

Liquid filling

0 : Dry

1 : Glycerin

2 : Silicon

Mounting

1 : Direct bottom connection to flange

Option

Refer to option table

Pressure range

Refer to pressure range table

Unit of measurement

B : bar

M : MPa

P : psi

D : dual scale

X : others

Process connection / Flange

Refer to flange rating table

Pressure range code, unit bar

Code	Range	Code	Range	Code	Range	Code	Range
R05	-1...24	R15	-1...1.5	R26	0...1.6	R35	0...16
R07	-1...15	R17	-1...0.6	R28	0...2.5	R37	0...25
R09	-1...9	R19	-1...0	R30	0...4	R39	0...40
R11	-1...5	R21	0...0.6	R32	0...6	RYY	Others
R13	-1...3	R23	0...1	R33	0...10		

Option code

Code	Description	Code	Description
ND	New dial design	TP	St. stell tag plate, 60 x 20 x 0.5t
NF	New dial face printing cost per pcs	MC	Manufacture calibration certificate
GM	Green marking per pcs	KC	KOLAS Ilac-MRA calibration certificate
CD	New dial face design with company logo	R	Reed switch
RS	Restrictor screw in socket hole for high pulsation	SN	Snubber
UC	U-calmp for back connection, steel	AD	Adaptor
NO	"USE No OIL" per pcs, at least ≥ 10 pcs	CC	Certificate of conformance / orign
OF	Oval 3-hole front flange	PM	2" Pipe mounting bracket
MP	Maximum pointer	NC	Ni-Cr Plate
BB	Bayonet bezel ring for MBX5	AL	Aluminium pointer for MBX3

How to Order

MDI, MAX.511.B11RBR39.GM

MDI, MAX.511, 100mm, Bottom Connection, Glycerine, 1/2" 150# RF, 0...40 bar, Green marking

Dimension in mm [inch.]

Flange per DIN2501

DN [mm]	PN [bar]	Dimensions [mm]							Weight [kg]
		D	k	d ₄	b	f	H	G ₁	
15	10/40	95	65	45	28	2	56	4 x M 12	1.56
	63/100	105	75	45	25	2	53	4 x M 12	2.00
	160	105	75	45	25	2	53	4 x M 12	2.13
	250	130	90	45	26	2	54	4 x M 12	3.20
20	10/40	105	75	58	25	2	53	4 x M 12	1.87
25	10/40	115	85	68	22	2	50	4 x M 12	2.10
	63/100	140	100	68	24	2	52	4 x M 12	3.20
	160	140	100	68	24	2	52	4 x M 12	3.60
	250	150	105	68	28	2	56	4 x M 12	4.00
40	10/40	150	110	88	22	2	50	4 x M 12	3.14
	63/100	170	125	88	26	2	54	4 x M 12	4.90
	160	170	125	88	28	2	56	4 x M 12	5.24
	250	185	135	88	34	2	62	4 x M 12	6.94

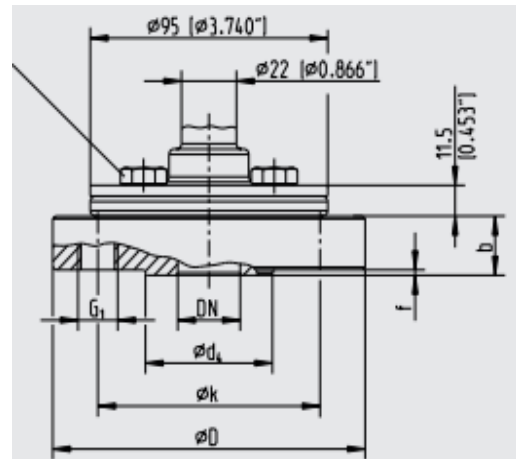

Threaded connection:

- 4x to 100 bar
- 8x to 250 bar
- 8x with metal sealing

Legend:

- Mb Effective diameter of diaphragm
- D Outer diameter of diaphragm seal
- b Flange thickness
- d₄ Sealing face diameter
- f Height of raised face
- k Pitch circle diameter
- G₁ Thread
- x Number of screws

Flange per ANSI B 16.5

DN [inch]	PN [class #]	Dimensions [mm]						
		D	k	d ₄	b	f	H	G ₁
1/2"	150	95	60.5	35	28	2	56	4 x 1/2"
	300	105	75	45	25	2	53	4 x 1/2"
	600	105	75	45	25	2	53	4 x 1/2"
	1500	130	90	45	26	2	54	4 x 3/4"
3/4"	150	100	70	43	28	2	56	4 x 1/2"
	300	120	82.5	43	22	2	50	4 x 5/8"
	600	120	82.5	43	25	7	53	4 x 5/8"
	1500	130	89	43	32	7	60	4 x 3/4"
1"	150	110	79.5	51	22	2	56	4 x 1/2"
	300	125	89	51	22	2	50	4 x 5/8"
	600	125	89	51	25	7	53	4 x 5/8"
	1500	150	102	51	36	7	64	4 x 7/8"
1 1/2"	150	130	98.5	73	22	2	56	4 x 1/2"
	300	155	115	73	22	2	50	4 x 3/4"
	600	155	115	73	30	7	58	4 x 3/4"
	1500	180	124	73	39	7	67	4 x 1"

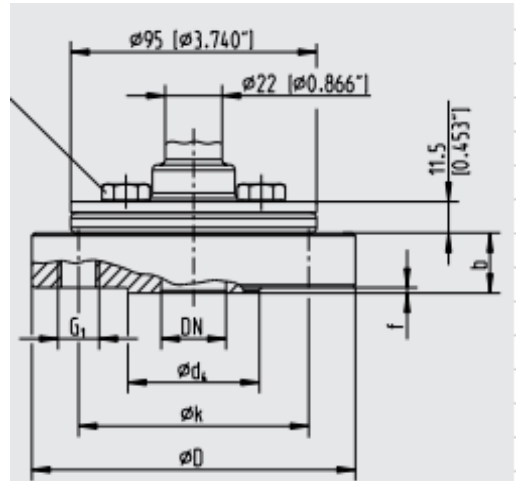

Threaded connection:

- 4x to 100 bar
- 8x to 250 bar
- 8x with metal sealing

Legend:

- Mb Effective diameter of diaphragm
- D Outer diameter of diaphragm seal
- b Flange thickness
- d₄ Sealing face diameter
- f Height of raised face
- k Pitch circle diameter
- G₁ Thread
- x Number of screws

Outline drawing

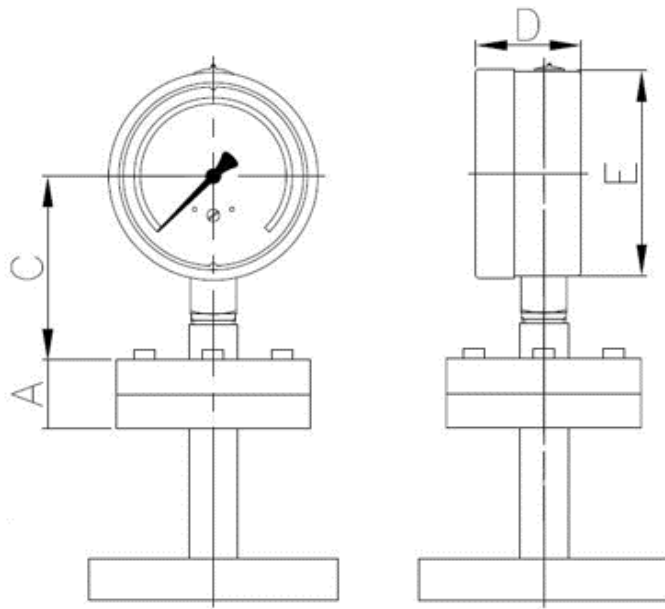

Dimension (mm)

Diaphragm seal	A	B	C	D	E
MDI + MAX.51x	19	-	80	48	99